

SECTION CL

CONTENTS

HYDRAULIC CLUTCH CONTROL	CL- 2	PILOT BUSHING	CL- 8
CLUTCH PEDAL	CL- 2	SERVICE DATA AND	
CLUTCH MASTER CYLINDER	CL- 3	SPECIFICATIONS (S.D.S.)	CL- 9
OPERATING CYLINDER	CL- 4	GENERAL SPECIFICATIONS	CL- 9
CLUTCH LINE	CL- 4	INSPECTION AND ADJUSTMENT	CL- 9
BLEEDING CLUTCH SYSTEM	CL- 5	TIGHTENING TORQUE	CL-10
CLUTCH UNIT	CL- 6	TROUBLE DIAGNOSES AND	
CLUTCH DISC AND COVER	CL- 6	CORRECTIONS	CL-11
RELEASE BEARING	CL- 7	SPECIAL SERVICE TOOLS	CL-13

Refer to Section MA (Clutch) for:

- CHECKING CLUTCH PEDAL HEIGHT AND FREE PLAY

HYDRAULIC CLUTCH CONTROL

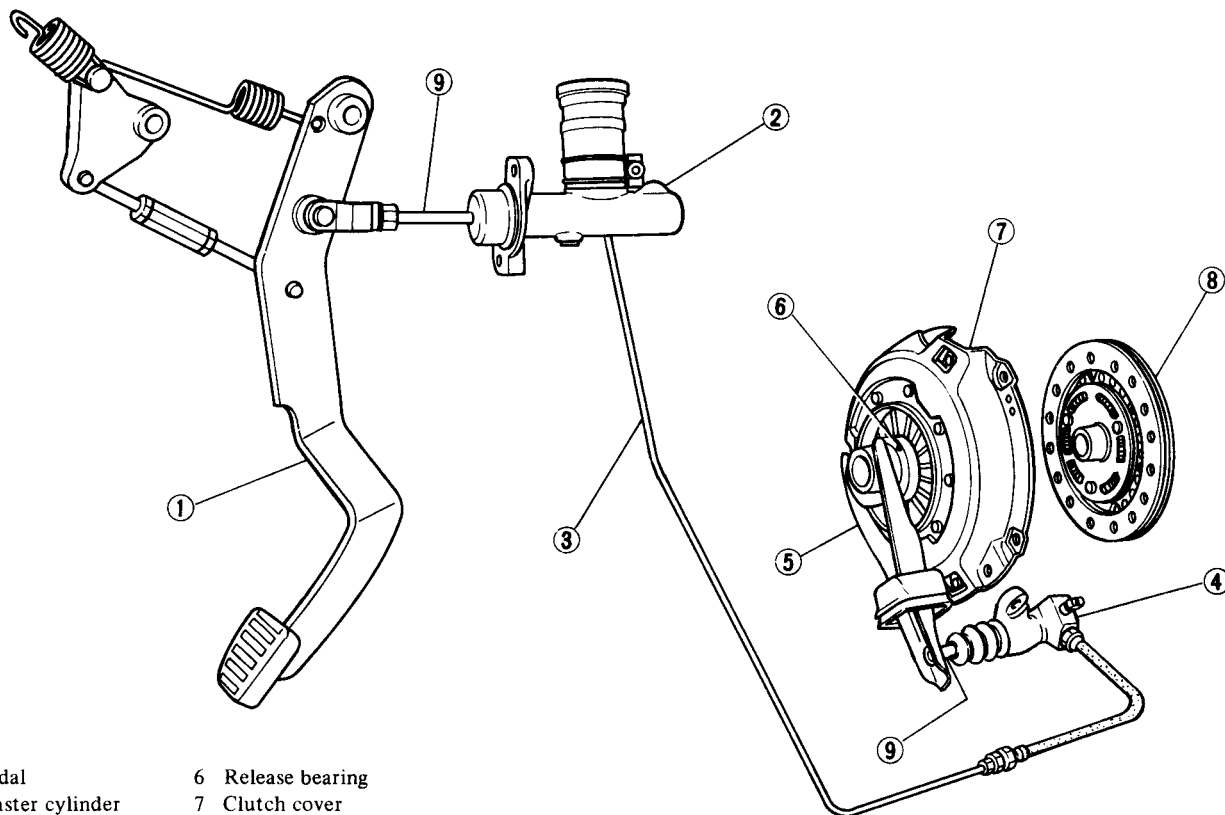

- | | |
|--------------------------|-------------------|
| 1 Clutch pedal | 6 Release bearing |
| 2 Clutch master cylinder | 7 Clutch cover |
| 3 Clutch piping | 8 Clutch disc |
| 4 Operating cylinder | 9 Push rod |
| 5 Withdrawal lever | |

CL367

CLUTCH PEDAL

REMOVAL

1. Remove instrument lower cover and floor assistant nozzle.
2. Remove snap pin (7) and clevis pin, disconnect push rod from pedal assembly.
3. Remove E-ring adjusting rod.
4. Remove fulcrum bolt.
5. Remove springs and assist spring clutch lever.

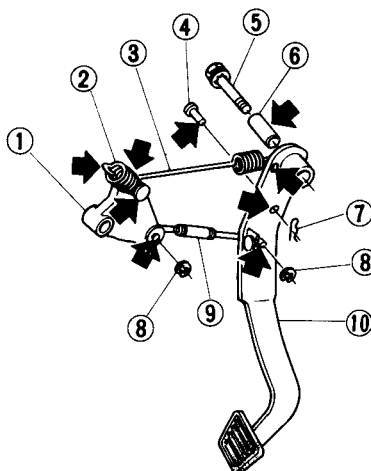

← : greasing point

- | | |
|---------------------------------|-----------------|
| 1 Assist spring
clutch lever | 6 Collar |
| 2 Return spring | 7 Snap pin |
| 3 Assist return spring | 8 E-ring |
| 4 Clevis pin | 9 Adjusting rod |
| 5 Fulcrum bolt | 10 Pedal |

SCL042

INSPECTION

Check clutch pedal parts for the following items, correcting as necessary.

1. Bent pedal.
2. Weakened return spring.
3. Worn or deformed clevis pin and pedal boss.
4. Cracks at welded part.

INSTALLATION

Install clutch pedal in the reverse procedures of removal. Observe the following:

1. Apply multi-purpose grease to the friction surface.
2. Adjust clutch pedal height. Refer to Section MA.

CLUTCH MASTER CYLINDER

REMOVAL

1. Remove snap pin from clevis pin.
2. Pull out clevis pin.
3. Disconnect clutch tube from master cylinder.
4. Remove windshield washer tank and dropping resistor for EFI from body and put them at a position where they won't interfere with master cylinder. Then remove master cylinder.

DISASSEMBLY

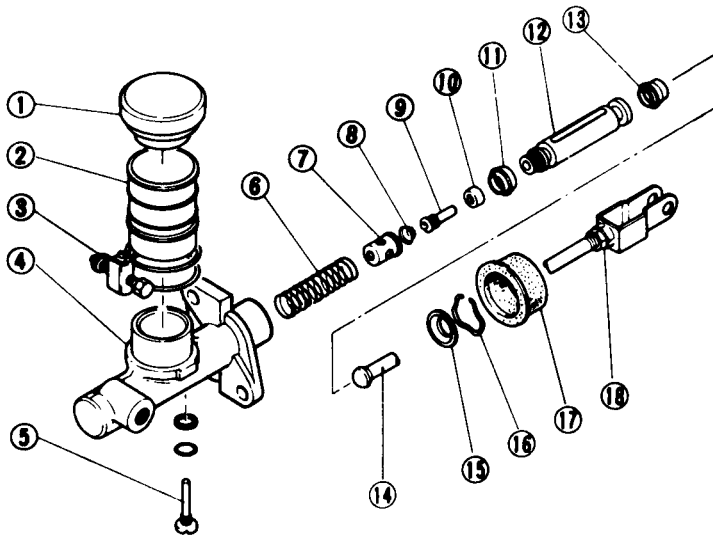

- | | | | |
|------------------------|--------------------|------------------|-----------------|
| 1 Reservoir cap | 6 Return spring | 11 Primary cup | 16 Stopper ring |
| 2 Reservoir | 7 Spring seat | 12 Piston | 17 Dust cover |
| 3 Reservoir band | 8 Valve spring | 13 Secondary cup | 18 Lock nut |
| 4 Cylinder body | 9 Supply valve rod | 14 Push rod | |
| 5 Supply valve stopper | 10 Supply valve | 15 Stopper | |

CL345

INSPECTION

CAUTION:

To clean or wash all parts of master cylinder, clean brake fluid must be used. Never use mineral oils such as gasoline and kerosene. It will ruin the rubber parts of the hydraulic system.

1. Check cylinder bore and piston for score or rust and if found, replace.
2. Check cylinder bore and piston for wear. If the clearance between cylinder bore and piston exceeds the

specified value, replace piston assembly or master cylinder assembly.

Clearance between cylinder bore and piston:

Less than 0.15 mm
(0.0059 in)

3. Check the condition of piston cup and dust cover. Always replace them after disassembly.
4. Check all recesses, openings and internal passages to ensure that they are clean and free from foreign matter.

ASSEMBLY

Assemble clutch master cylinder in the reverse order of disassembly. Observe the following:

1. Dip piston cup in brake fluid before installing. Make sure that it is correctly faced in position.
2. Apply a coating of brake fluid to cylinder and piston when assembling.

Ⓣ : Supply valve stopper
1.5 - 2.9 N·m
(0.15 - 0.3 kg·m,
1.1 - 2.2 ft·lb)

INSTALLATION

Install clutch master cylinder in the reverse order of removal. Observe the following:

1. Bleed air out of hydraulic system. Refer to Bleeding Clutch System for bleeding.
2. Adjust pedal height. Refer to Section MA.

Ⓣ : Master cylinder to dash panel securing nut

7.8 - 10.8 N·m
(0.8 - 1.1 kg·m,
5.8 - 8.0 ft·lb)

Clutch tube flare nut
15 - 18 N·m
(1.5 - 1.8 kg·m,
11 - 13 ft·lb)

CAUTION:

When connecting clutch tube, use Flare Nut Torque Wrench GG94310000.

Note: When tightening flare nut, hold pipe by hand to prevent it from twisting.

OPERATING CYLINDER

REMOVAL

1. Disconnect clutch tube from clutch hose at the bracket on side member.

CAUTION:

When disconnecting clutch tube, use suitable flare nut wrench. Never use an open end wrench or adjustable wrench.

2. Remove lock spring, then disengage hose from bracket.
3. Remove clutch hose from operating cylinder.
4. Remove operating cylinder.

DISASSEMBLY

1. Remove push rod and dust cover.
2. Remove piston and piston cup as an assembly.

Note: Do not reuse piston cup and dust cover after removal.

3. Remove bleeder screw.

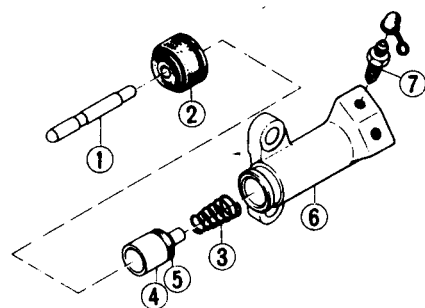

- | | |
|-----------------|----------------------|
| 1 Push rod | 5 Piston cup |
| 2 Dust cover | 6 Operating cylinder |
| 3 Piston spring | 7 Bleeder screw |
| 4 Piston | |

CL222

INSPECTION

Visually inspect all disassembled parts and replace parts which are worn or damaged too badly beyond specifications.

CAUTION:

To clean or wash all parts of operating cylinder, clean brake fluid must be used.

Never use mineral oils such as gasoline and kerosene. It will ruin the rubber parts of the hydraulic system.

1. Check cylinder bore and piston for score or rust and, if found, replace.
2. Check cylinder bore and piston for wear. If clearance between cylinder bore and piston is more than the specified value, replace piston or operating cylinder assembly.

Clearance between cylinder bore and piston:

Less than 0.15 mm (0.0059 in)

3. Check bleeder hole to be sure that it is clean.

ASSEMBLY

Assemble operating cylinder in the reverse order of disassembly. Observe the following:

1. Prior to assembly, dip a new piston cup in clean brake fluid. To install piston cup on piston, pay particular attention to its direction.

Note: Replace piston cup and dust cover with new ones.

2. Dip cylinder and piston in clean brake fluid before assembly.

INSTALLATION

Install operating cylinder in the reverse order of removal. Observe the following:

Bleed air thoroughly from clutch hydraulic system. Refer to Bleeding Clutch System for bleeding.

Note:

- a. Use new gasket.
- b. When operating cylinder is removed from, or installed on, clutch housing without disconnecting clutch hose from operating cylinder, loosen bleeder screw so that push rod moves lightly.
- c. Exercise care not to warp or twist clutch hose. Be sure to install clutch hose away from exhaust tube.
- d. When tightening flare nut, hold pipe by hand to prevent it from twisting.

CAUTION:

When connecting clutch tube, use Flare Nut Torque Wrench GG94310000.

⊕ : Bleeder screw

6.9 - 8.8 N·m
(0.7 - 0.9 kg·m,
5.1 - 6.5 ft·lb)

Operating cylinder to clutch housing securing bolts

30 - 40 N·m
(3.1 - 4.1 kg·m,
22 - 30 ft·lb)

Clutch hose to operating cylinder

16 - 21 N·m
(1.6 - 2.1 kg·m,
12 - 15 ft·lb)

Flare nut

15 - 18 N·m
(1.5 - 1.8 kg·m,
11 - 13 ft·lb)

CLUTCH LINE

INSPECTION

Check clutch lines (tube and hose) for evidence of cracks, deterioration or other damage. Replace if necessary.

If leakage occurs at or around joints, retighten and, if necessary, replace damaged parts.

REMOVAL

CAUTION:

When disconnecting clutch tube, use suitable flare nut wrench. Never use an open end wrench or adjustable wrench.

1. Disconnect clutch tube from clutch hose at bracket on side member.
2. Remove lock spring, then disengage hose from bracket.
3. Remove clutch hose from operating cylinder.
4. Disconnect clutch tube from master cylinder.
5. Remove clamp fixing clutch tube to dash panel.

INSTALLATION

Wipe the opening ends of hydraulic line to remove any foreign matter before making connections.

1.
 - (1) Connect clutch tube to master cylinder with flare nut.
 - (2) Fix clutch tube to dash panel with clamp.
 - (3) Then tighten flare nut.

Ⓣ : **Flare nut**
15 - 18 N·m
(1.5 - 1.8 kg·m,
11 - 13 ft·lb)

2. Install clutch hose on operating cylinder with a gasket in place.

Note: Use new gasket.

Ⓣ : **16 - 21 N·m**
(1.6 - 2.1 kg·m,
12 - 15 ft·lb)

3. Engage opposite end of hose with bracket. Install lock spring fixing hose to bracket.

Note:

- a. When tightening flare nut, hold pipe by hand to prevent it from twisting.
- b. Exercise care not to warp or twist clutch hose.

4. Connect clutch tube to hose with flare nut and tighten it.
5. Check distance between clutch line and adjacent parts (especially between hose and exhaust tube).
6. Bleed air out of hydraulic system. Refer to Bleeding Clutch System for bleeding.

CAUTION:

When tightening flare nut, use Flare Nut Wrench GG94310000.

BLEEDING CLUTCH SYSTEM

The hydraulic clutch system must be bled whenever clutch line has been disconnected or air has entered it.

When pedal action has a "spongy" feeling, it is an indication that air has entered the system.

Bleeding clutch system is an essential part of regular clutch service.

1. Remove cap of reservoir and top up with recommended brake fluid.
2. Thoroughly clean mud and dust from bleeder screw of operating cylinder so that outlet hole is free from any foreign material. Install bleeder hose (vinyl hose) on bleeder screw.

Place the other end of it in a container filled with brake fluid.

3. Have a co-worker depress clutch pedal two or three times. With clutch pedal depressed fully, loosen bleeder screw to bleed air out of clutch system.

4. Close bleeder screw quickly as clutch pedal is on down stroke.
5. Allow clutch pedal to return slowly with bleeder screw closed.
6. Repeat steps 3 through 5 until no air bubble shows in the vinyl hose.

Ⓣ : **Bleeder screw**
6.9 - 8.8 N·m
(0.7 - 0.9 kg·m,
5.1 - 6.5 ft·lb)

7. Depress and release clutch pedal several times; then, check for external hydraulic leaks at connections.

Note:

- a. Brake fluid containing air is white and has visible air bubbles.
- b. Brake fluid containing no air runs out of bleeder screw in a solid stream without air bubbles.
- c. Pay close attention to clutch fluid level in reservoir during bleeding operation.
- d. Pour brake fluid into reservoir up to the specified level.

CAUTION:

- a. Do not reuse brake fluid drained during bleeding operation.
- b. Exercise care not to splash brake fluid on exterior finish as it will damage the paint.
- c. When tightening flare nut, use Flare Nut Torque Wrench GG94310000.

CLUTCH UNIT

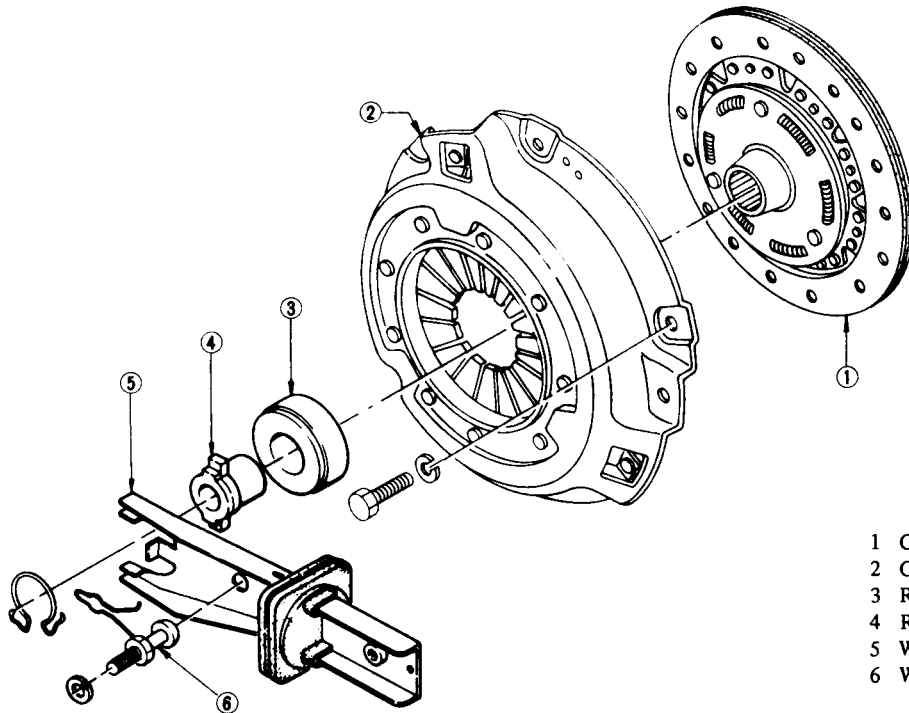

- 1 Clutch disc assembly
- 2 Clutch cover assembly
- 3 Release bearing
- 4 Release sleeve
- 5 Withdrawal lever
- 6 Withdrawal lever ball pin

CL319

CLUTCH DISC AND COVER

REMOVAL

1. Remove transmission from engine. Refer to Removal (Section MT).
2. Insert Clutch Aligning Bar KV30100100 into clutch disc hub until it will no longer go. It is important to support weight of clutch disc in the steps that follow.

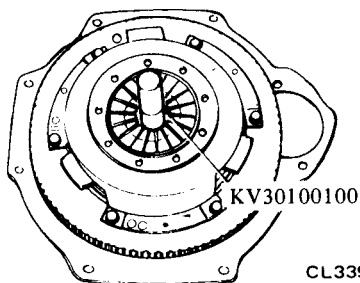

CL339

3. Loosen bolts attaching clutch cover to flywheel, one turn each at a time, until spring pressure is released. Be sure to turn them out in a crisscross fashion.

4. Remove clutch disc and cover assembly.

INSPECTION

Wash all disassembled parts except disc assembly in suitable cleaning solvent to remove dirt and grease before making inspection and adjustment.

Flywheel and pressure plate

Check friction surface of flywheel and pressure plate for scoring or roughness. Slight roughness may be smoothed by using fine emery cloth. If surface is deeply scored or grooved, the part should be replaced.

Clutch disc assembly

Inspect clutch disc for worn or oily facings, loose rivets and broken or loose torsional springs.

1. If facings are oily, disc should be replaced. In this case, inspect transmis-

sion front cover oil seal, pilot bushing, engine rear oil seals and other points for oil leakage.

2. The disc should also be replaced when facings are worn locally or worn down to the specified limit.

Wear limit of facing "A":

Less than 0.3 mm (0.012 in)

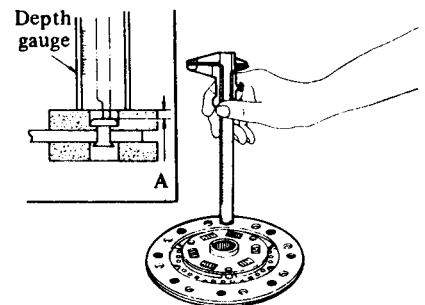

CL336

3. Check disc plate for runout whenever the old disc or a new one is installed.

4. If runout exceeds the specified value at outer circumference of facing, replace or repair disc.

Clutch

Runout limit

(total indicator reading):
Less than 0.5 mm (0.020 in)
at "R"

L28E engine model
107.5 mm (4.23 in)
L28ET engine model
115 mm (4.53 in)

CAUTION:

When repairing disc plate, never hold it forcibly with pliers or bend it excessively; otherwise facing will be damaged.

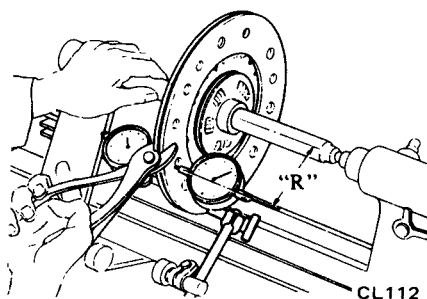

5. Check fit of disc hub on transmission main drive gear splines for smooth sliding. If splines are worn, clutch disc or main drive gear should be replaced; that is, backlash exceeds the specified value at outer edge of clutch disc.

Backlash:

Less than 0.4 mm (0.016 in)

Clutch cover assembly

1. Check the end surface of diaphragm spring for wear. If excessive wear is found, replace clutch cover assembly.
2. Measure height of diaphragm springs as outlined below:

(1) Place Distance Piece
ST20050100 on Base Plate
ST20050010 and then tighten clutch cover assembly on base plate by using Set Bolts ST20050051.

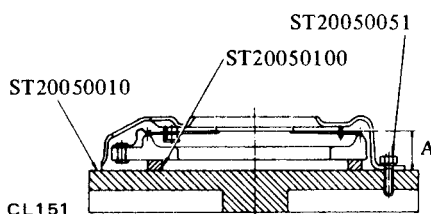

(2) Measure height "A" at several points with a vernier caliper depth gauge. If height "A" of spring end is beyond the specified value, adjust spring height with Diaphragm Adjusting Wrench ST20050240.

Diaphragm spring height "A":

C225S model
33.0 - 35.0 mm
(1.299 - 1.378 in)

C240S model
37.5 - 39.5 mm
(1.476 - 1.555 in)

If necessary, replace clutch cover assembly. Also, unevenness of diaphragm spring toe height should be within the specified limit.

Unevenness of diaphragm spring toe height:

Less than 0.5 mm (0.020 in)

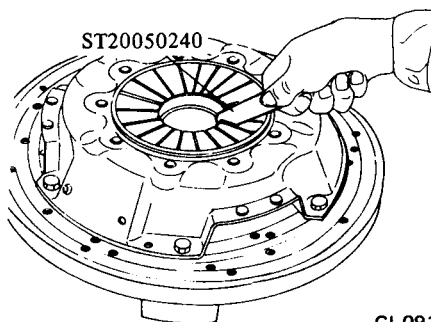

3. Inspect thrust rings for wear or damage. As these parts are invisible from outside, shake cover assembly up and down to listen for chattering noise, or lightly hammer on rivets for a slightly cracked noise. Any of these noises indicates need of replacement as a complete assembly.

INSTALLATION

1. Apply a light coat of grease (including molybdenum disulphide) to transmission main drive gear splines.

Slide clutch disc on main drive gear several times. Remove clutch disc and wipe off excess lubricant pushed off by disc hub.

Note: Take special care to prevent grease or oil from getting on clutch facing.

2. Reinstall clutch disc and clutch cover assembly. Support clutch disc and cover assemblies with Clutch Aligning Bar KV30100100.

Note: Be sure to keep disc facings, flywheel and pressure plate clean and dry.

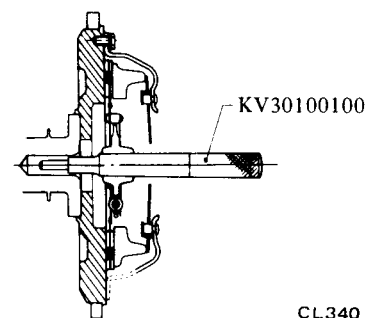

3. Install bolts to tighten clutch cover assembly to flywheel squarely. Each bolt should be tightened one turn at a time in a crisscross fashion.

ⓧ : Clutch cover bolt

16 - 21 N·m
(1.6 - 2.1 kg·m,
12 - 15 ft·lb)

Note: Dowels are used to locate clutch cover on flywheel properly.

4. Remove clutch aligning bar.
5. Reinstall transmission. Refer to Installation (Section MT).

RELEASE BEARING

REMOVAL

1. Remove transmission from engine. Refer to Removal (Section MT).
2. Disconnect retainer spring from bearing sleeve.
3. Remove release bearing and sleeve as an assembly from transmission case front cover.

Clutch

4. Take clutch release bearing out from bearing sleeve, using a universal puller and a suitable adapter.

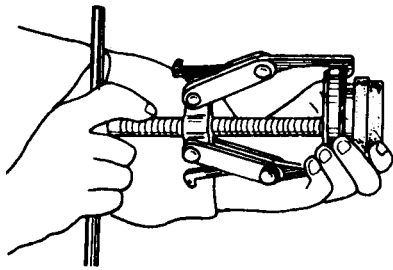

CL145

- (2) Contact surfaces of withdrawal lever, lever ball pin and bearing sleeve.
- (3) Bearing sleeve sliding surface of transmission case front cover.

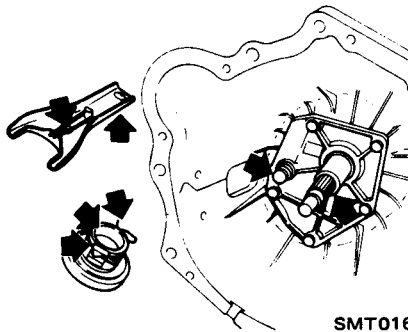

SMT016

3. Remove pilot bushing in crankshaft by Pilot Bushing Puller ST16610001.

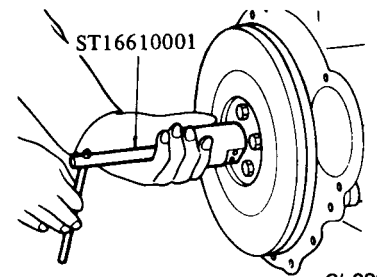

CL088

INSPECTION

Check for abnormal wear on contact surface of withdrawal lever, ball pin and bearing sleeve.

Hold bearing inner race and rotate outer race while applying pressure to it. If the bearing rotation is rough or noisy, replace bearing.

INSTALLATION

1. Assemble release bearing on sleeve, using a press.

Note: Do not depress outer race.

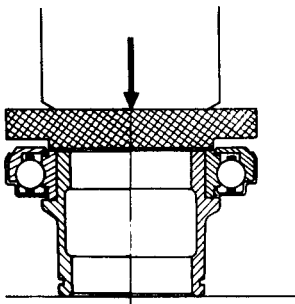

CL117

2. Before or during assembly, lubricate the following points with a light coat of lithium-based grease including molybdenum disulphide.

(1) Inner groove of release bearing sleeve.

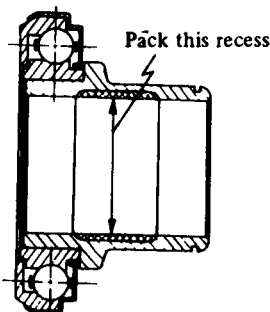

CL093

(4) Transmission main drive gear splines.

Note: A small amount of grease should be coated to the above points. If too much lubricant is applied, it will run out on the friction plates when hot, resulting in damaged clutch disc facings.

3. After lubricating, install withdrawal lever, release bearing and sleeve assembly in position. Connect them with retainer spring.

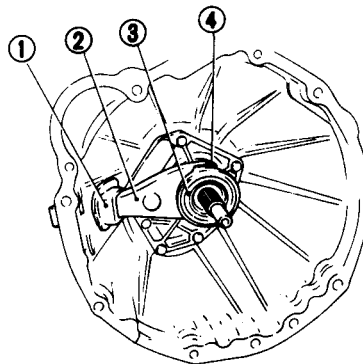

CL311

- | | |
|--------------------|-------------------|
| 1 Dust cover | 3 Release bearing |
| 2 Withdrawal lever | 4 Retainer spring |

4. Reinstall transmission. Refer to Installation (Section MT).

PILOT BUSHING

REMOVAL

1. Remove transmission from engine. Refer to Removal (Section MT).
2. Remove clutch disc and cover assembly. Refer to Clutch Disc and Cover for removal.

INSPECTION

Check pilot bushing for fit in bore of crankshaft.

Check inner surface of pilot bushing for wear, roughness or bell-mouthed condition. If pilot bushing is worn or damaged, replace. When bushing is damaged, be sure to check transmission main drive gear at the same time.

INSTALLATION

1. Before installing a new bushing, thoroughly clean bushing hole.
2. Insert pilot bushing until distance between flange end and pilot bushing is the specified distance A. Bushing need not be oiled.

Distance "A":
4.0 mm (0.157 in)

Note: When installing pilot bushing, be careful not to damage edge of pilot bushing and not to insert excessively.

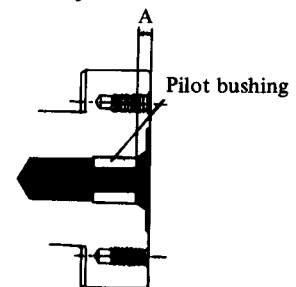

EM719

3. Install clutch disc and clutch cover assembly. Refer to Clutch Disc and Cover for installation.
4. Install transmission. Refer to Installation (Section MT).

SERVICE DATA AND SPECIFICATIONS (S.D.S.)

GENERAL SPECIFICATIONS

CLUTCH CONTROL SYSTEM

Type of clutch control	Hydraulic
------------------------	-----------

CLUTCH MASTER CYLINDER

Inner diameter	mm (in)	15.88 (5/8)
----------------	---------	-------------

CLUTCH COVER

L28E engine model

Item	Model	
	2 seater	2 + 2 seater
Type	C225S	C240S
Full load	N (kg, lb) 5,394 (550, 1,213)	4,904 (500, 1,103)

L28ET engine model

Type	C240S
Full load	N (kg, lb) 5,884 (600, 1,323)

CLUTCH OPERATING CYLINDER

Unit: mm (in)

Type	Non-adjustable
Inner diameter	19.05 (3/4)

CLUTCH DISC

L28E engine model

Unit: mm (in)

Item	Model	
	2 seater	2 + 2 seater
Type	225CBL	240TBL
Facing size Outer dia. x Inner dia. x Thickness	225 x 150 x 3.5 (8.86 x 5.91 x 0.138)	240 x 150 x 3.5 (9.45 x 5.91 x 0.138)
Thickness of disc assembly	8.25 - 8.95 (0.3248 - 0.3524)	8.55 - 9.25 (0.3366 - 0.3642)
Free		
Installed	7.6 - 8.0 (0.299 - 0.315)	7.8 - 8.2 (0.307 - 0.323)
Number of torsion springs	6	6

L28ET engine model

Unit: mm (in)

Type	240TBL
Facing size Outer dia. x Inner dia. x Thickness	240 x 160 x 3.5 (9.45 x 6.30 x 0.138)
Thickness of disc assembly	8.55 - 9.25 (0.3366 - 0.3642)
Free	
Installed	7.8 - 8.2 (0.307 - 0.323)
Number of torsion springs	6

INSPECTION AND ADJUSTMENT

CLUTCH PEDAL

Unit: mm (in)

Pedal height "H"	203 (7.99)
Pedal free play "A"	1 - 5 (0.04 - 0.20)

CLUTCH MASTER CYLINDER

Clearance between cylinder bore and piston	mm (in)	Less than 0.15 (0.0059)
---	---------	-------------------------

CLUTCH OPERATING CYLINDER

Clearance between cylinder bore and piston	mm (in)	Less than 0.15 (0.0059)
---	---------	-------------------------

CLUTCH DISC

Unit: mm (in)

Item	Model	
	C225S	C240S
Wear limit of facing surface to rivet head	0.3 (0.012)	
Runout limit	0.5 (0.020)	0.5 (0.020)
Distance of runout checking point (from the hub center)	107.5 (4.23)	115 (4.53)
Maximum backlash of spline (at outer edge of disc)	0.4 (0.016)	

CLUTCH COVER

Unit: mm (in)

Item	Model	
	C225S	C240S
Diaphragm spring height	33.0 - 35.0 (1.299 - 1.378)	37.5 - 39.5 (1.476 - 1.555)
Unevenness of diaphragm spring toe height	Less than 0.5 (0.020)	

PILOT BUSHING

Inserted distance of pilot bushing mm (in)	4.0 (0.157)
---	-------------

TIGHTENING TORQUE

Unit	N-m	kg-m	ft-lb
Pedal stopper (clutch switch) lock nut	9.1 - 11.8 (12 - 15)	0.93 - 1.2 (1.2 - 1.5)	6.7 - 8.7 (9 - 11)
Master cylinder push rod lock nut	7.8 - 11.8	0.8 - 1.2	5.8 - 8.7
Operating cylinder bleeder screw	6.9 - 8.8	0.7 - 0.9	5.1 - 6.5
Master cylinder to dash panel securing nut	7.8 - 10.8	0.8 - 1.1	5.8 - 8.0
Master cylinder reservoir band	2.5 - 3.9	0.25 - 0.4	1.8 - 2.9
Master cylinder supply valve stopper	1.5 - 2.9	0.15 - 0.3	1.1 - 2.2
Clutch tube flare nut	15 - 18	1.5 - 1.8	11 - 13
Operating cylinder to clutch housing securing bolt	30 - 40	3.1 - 4.1	22 - 30
Clutch hose to operating cylinder	16 - 21	1.6 - 2.1	12 - 15
Clutch cover bolt	16 - 21	1.6 - 2.1	12 - 15





TROUBLE DIAGNOSES AND CORRECTIONS

Condition	Probable cause and testing	Corrective action
Clutch slips	<p>Slipping of clutch may be noticeable when any of the following symptoms is encountered during operation.</p> <ol style="list-style-type: none"> (1) Car will not respond to engine speed during acceleration. (2) Insufficient car speed. (3) Lack of power during uphill driving. <p>Some of the above conditions may also be attributable to engine problem. First determine whether engine or clutch is causing the problem.</p> <p>If slipping clutch is left unheeded, wear and/or overheating will occur on clutch facing to such an extent that it is no longer serviceable.</p> <p>TO TEST FOR SLIPPING CLUTCH, proceed as follows:</p> <p>During upgrade travelling, run engine at about 40 to 50 km/h (25 to 31 MPH) with gear shift lever in 3rd-speed position, shift into highest gear and at the same time rev up engine. If clutch is slipping, car will not readily respond to depression of accelerator pedal.</p>	
	<ul style="list-style-type: none"> ● Clutch facing worn excessively. ● Oil or grease on clutch facing. ● Warped clutch cover or pressure plate. 	<p>Replace.</p> <p>Replace.</p> <p>Repair or replace.</p>
Clutch drags	<p>Dragging clutch is particularly noticeable when shifting gears, especially into low gear.</p> <p>TO TEST FOR DRAGGING CLUTCH, proceed as follows:</p> <ol style="list-style-type: none"> (1) Start engine. Disengage clutch. Shift into reverse gear, and then into Neutral. Gradually increase engine speed, and again shift into reverse gear. If clutch is dragging, gear "grating" is heard when shifting gears from Neutral into Reverse. (2) Stop engine and shift gears. (Conduct this test at each gear position.) (3) In step (2), gears are shifted smoothly except 1st speed position at idling. <ol style="list-style-type: none"> a. If dragging is encountered at the end of shifting, check condition of synchro-mechanism in transmission. b. If dragging is encountered at the beginning of shifting, proceed to step (4) below. (4) Push change lever toward Reverse side, depress pedal to check for free travel of pedal. <ol style="list-style-type: none"> a. If pedal can be depressed further, check clutch for condition. b. If pedal cannot be depressed further, proceed to step (5) below. (5) Check clutch control. (Pedal height, pedal free play, etc.) <p>If any abnormal condition does not exist and if pedal cannot be depressed further, check clutch for condition.</p>	
	<ul style="list-style-type: none"> ● Clutch disc runout or warped. ● Wear or rust on hub splines in clutch disc. ● Diaphragm spring toe height out of adjustment or toe tip worn. ● Worn or improperly installed parts. 	<p>Replace.</p> <p>Clean and lubricate with grease, or replace.</p> <p>Adjust or replace.</p> <p>Repair or replace.</p>

Clutch

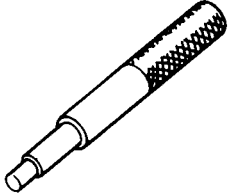
Condition	Probable cause and testing	Corrective action
Clutch chatters	Clutch chattering is usually noticeable when car is just rolled off with clutch partially engaged.	
	<ul style="list-style-type: none"> ● Weak or broken clutch disc torsion spring. 	Replace.
	<ul style="list-style-type: none"> ● Oil or grease on clutch facing. 	Replace.
	<ul style="list-style-type: none"> ● Clutch facing out of proper contact or clutch disc runout. 	Replace.
	<ul style="list-style-type: none"> ● Loose rivets. 	Replace.
	<ul style="list-style-type: none"> ● Warped pressure plate or clutch cover surface. 	Repair or replace.
	<ul style="list-style-type: none"> ● Unevenness of diaphragm spring toe height. 	Adjust or replace.
Noisy clutch	<ul style="list-style-type: none"> ● Loose engine mounting or deteriorated rubber. 	Retighten or replace.
	A noise is heard after clutch is disengaged.	
	<ul style="list-style-type: none"> ● Damaged release bearing. 	Replace.
	A noise is heard when clutch is disengaged.	
<ul style="list-style-type: none"> ● Insufficient grease on the sliding surface of bearing sleeve. 	Apply grease.	
<ul style="list-style-type: none"> ● Clutch cover and bearing are not installed correctly. 	Adjust.	
Clutch grabs	A noise is heard when car is suddenly rolled off with clutch partially engaged.	
	<ul style="list-style-type: none"> ● Damaged pilot bushing. 	Replace.
Clutch grabs	When grabbing of clutch occurs, car will not roll off smoothly from a standing start or clutch will be engaged before clutch pedal is fully depressed.	
	<ul style="list-style-type: none"> ● Oil or grease on clutch facing. 	Replace.
	<ul style="list-style-type: none"> ● Clutch facing worn or loose rivets. 	Replace.
	<ul style="list-style-type: none"> ● Wear or rust on splines in drive shaft and clutch disc. 	Clean or replace.
	<ul style="list-style-type: none"> ● Warped flywheel or pressure plate. 	Repair or replace.
	<ul style="list-style-type: none"> ● Loose mountings for engine or power train units. 	Retighten.

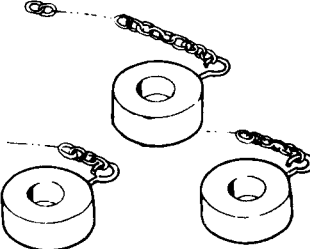
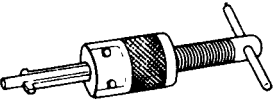
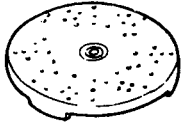
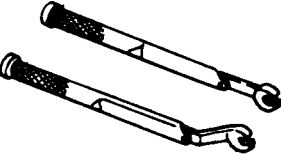
SPECIAL SERVICE TOOLS

Tool number & tool name	Kent-Moore No.	Tool number & tool name	Kent-Moore No.
	Reference page		Reference page
KV30100100 Clutch aligning bar 	—	ST20050240 Diaphragm spring adjusting wrench 	—
	CL-6		CL-7
ST20050100 Distance piece 	—	ST16610001 Pilot bushing puller 	J23907
	CL-7		CL-8
ST20050010 Base plate 	—	GG94310000 Flare nut torque wrench 	—
	CL-7		CL-3 CL-4 CL-5
ST20050051 Set bolts 	—		
	CL-7		